



1 Unpack box and make sure you have everything shown here.

Keypad Unit Gasket Slotted Screw (2x) Security Screw (2x) L Key

2 Prepare existing or install new single-gang junction box to which keypad unit will be mounted after wiring and testing. (Junction box is not included.)

What's what?

Important components labeled

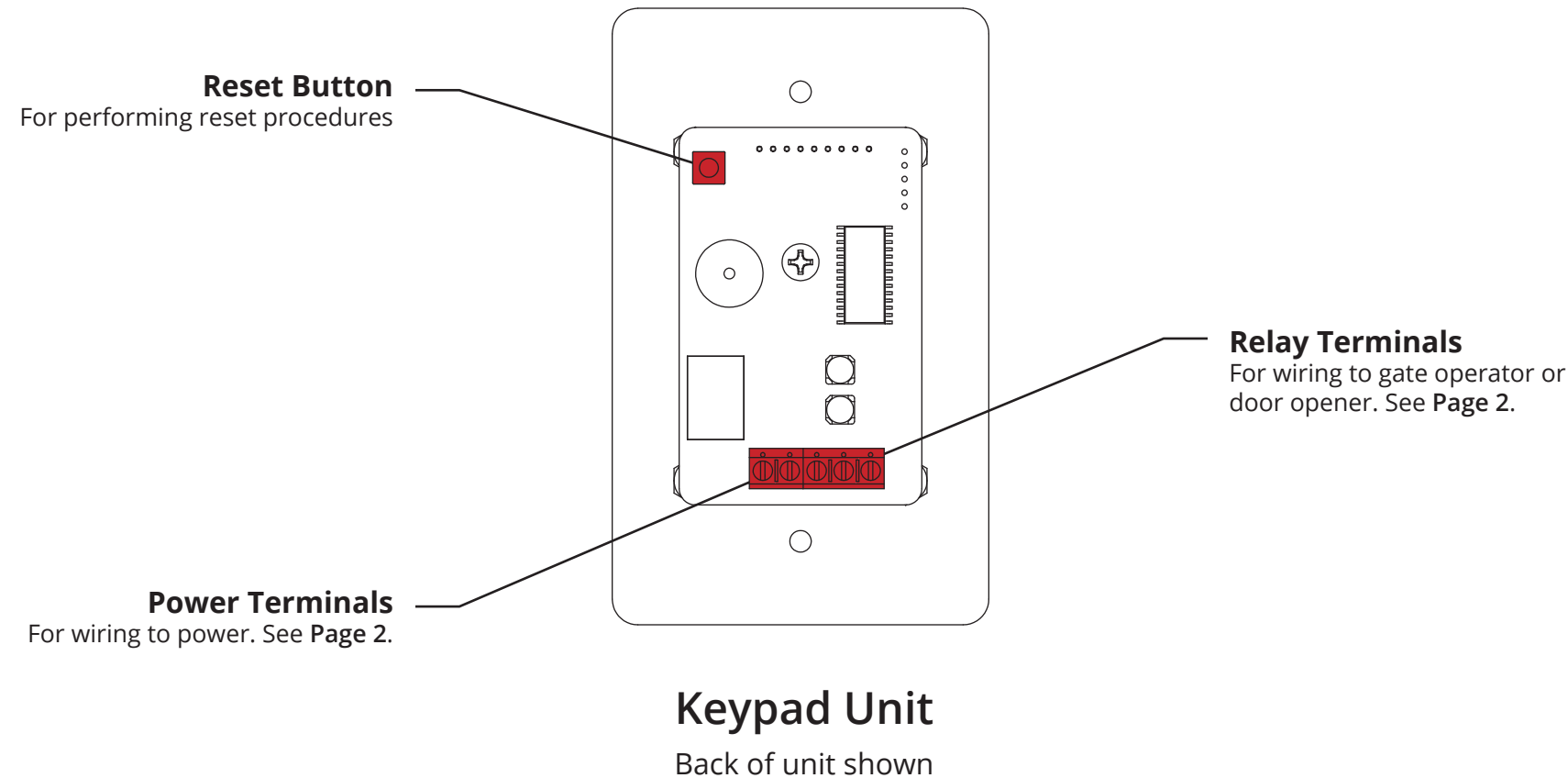

Continued on next page...

WARNING

AUTOMATIC GATES CAN CAUSE SERIOUS INJURY OR DEATH!

ALWAYS CHECK THAT THE GATE PATH IS CLEAR BEFORE OPERATING!

REVERSING OR OTHER SAFETY DEVICES SHOULD ALWAYS BE USED!

3a Connect wires.

Wiring for Gate Operator or Door Opener

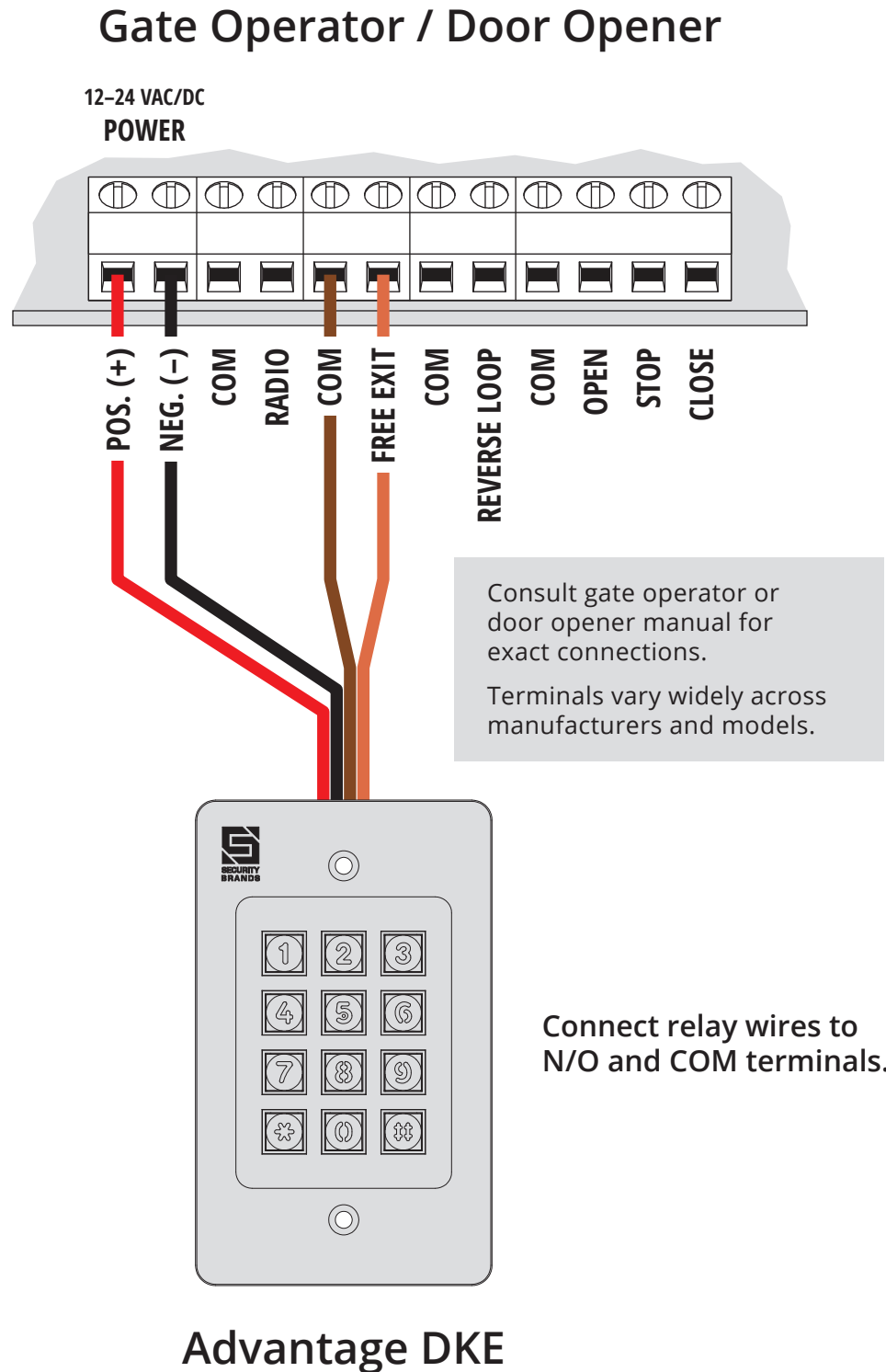

3b Connect wires.

Wiring for Electric Door Strike

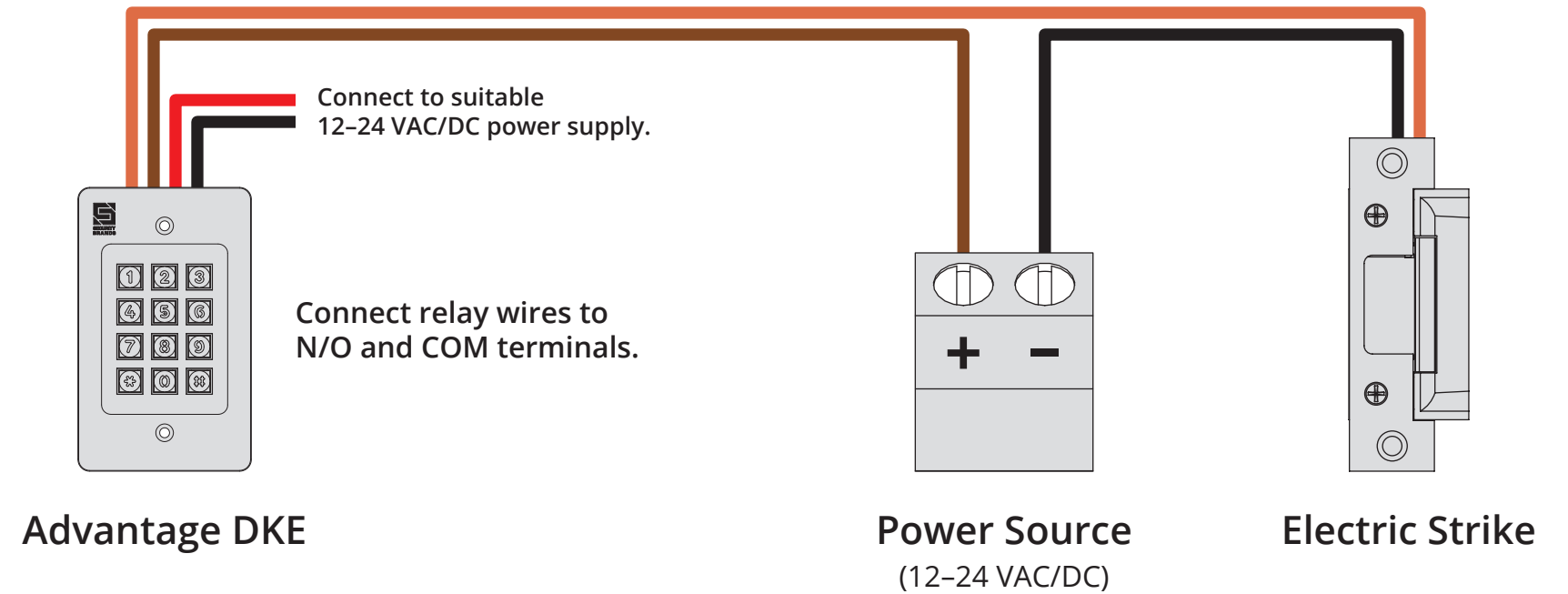

3c Connect wires.

Wiring for Mag Lock

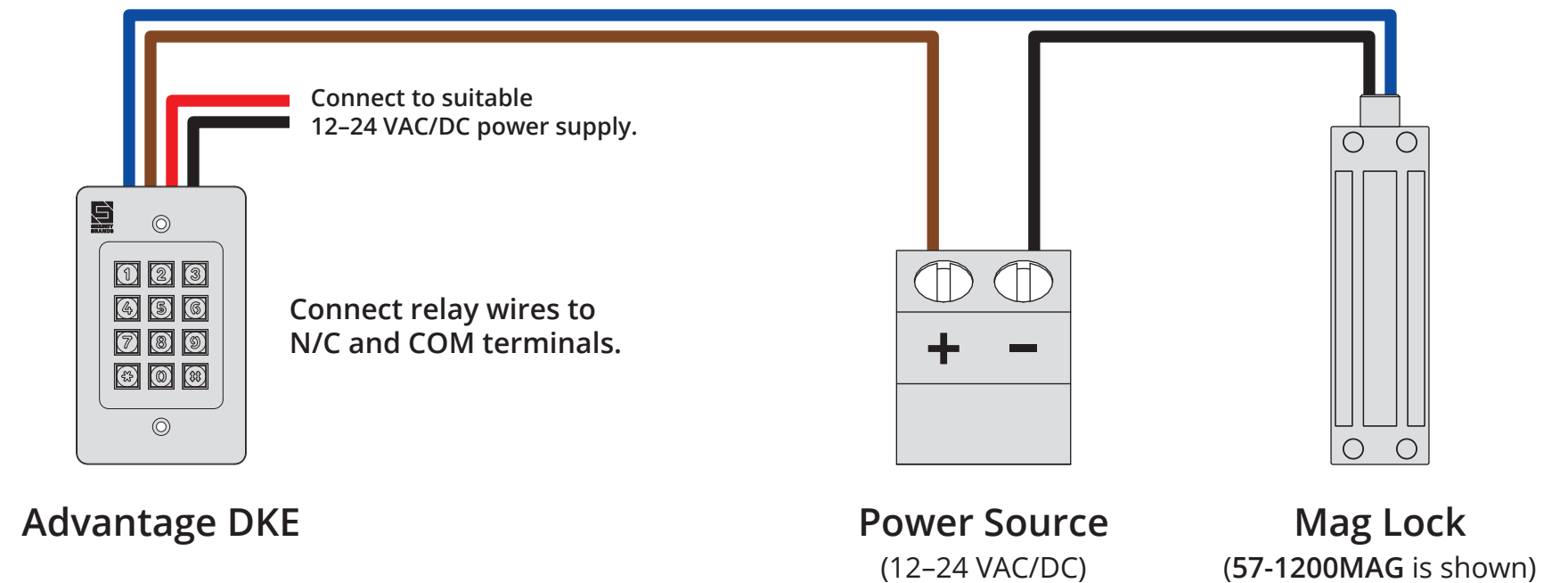

4 Add Access Code(s).
(To add multiple codes, enter each of them before pressing pound key)



NOTE: The Master Code is for programming only and will not trigger the relay. The green arrow indicates a "good" tone on the keypad. An incorrect entry will sound a "bad" tone.

5 Make sure gate path is clear; then enter access code on keypad and confirm gate opens.

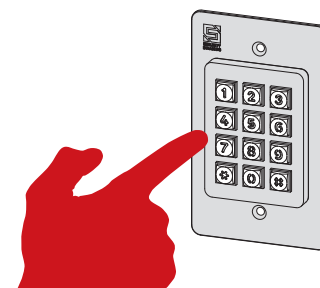

6 Secure keypad unit to junction box using either set of included screws.
(Gasket is optional if mounted indoors.)

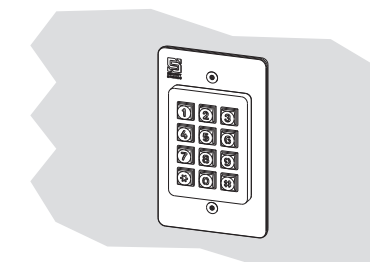

A1 Additional Programming

Delete Code(s)

(To delete multiple codes, enter each of them before pressing pound key)

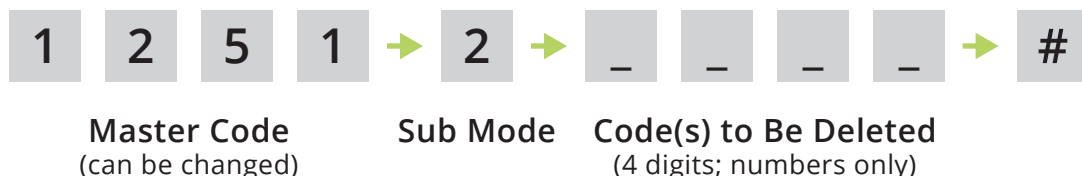

Change Master Code



Set Latch Code



Things to Know

The Star Key (*)

The star key deletes your current entry. If you happen to make a mistake keying in a code, simply press the star key to delete the entire entry and start over.

The Pound Key (#)

The pound key is good for one thing and one thing only: exiting Programming Mode. Whenever you're in Programming Mode, simply press the pound key to get out.

Master Reset Procedure

If for some reason the Master Code and/or Latch Code is forgotten, a reset procedure is available to remedy the situation.

This procedure can be found on **Page 4** of this guide.

NOTE: Green arrow indicates "good" tone on keypad. Always wait for good tone before moving on.



INSTALLATION COMPLETE!

Your system is ready to use.

Programming Sub Modes

- 1 Add Access Code(s)
- 2 Delete Code(s)
- 3 Change Master Code
- 4 Set Relay Output Time
- 5 Set Latch Code
- 0 Delete All Codes

A2 Additional Programming (continued)

Set Relay Output Time

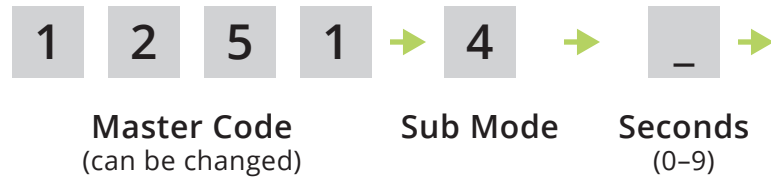

Delete All Codes (Cannot Be Undone)



NOTE: Green arrow indicates "good" tone on keypad. Always wait for good tone before moving on.

B Master Reset Procedure

This procedure is used if the Master Code is unknown, or if the Latch Code is unknown and the unit is in Latch Mode. All other codes will be retained after completing this procedure.

NOTE: If an error is made during these procedures, an "error" tone will sound, and you must start again from the beginning.

Step 1 - Unscrew mounting screws with L Key and remove keypad unit from junction box.

Step 2 - Disconnect power.

Loosen screw on power terminal block and remove one of two power wires.

Step 3 - Press and hold Reset Button; reconnect power; then release Reset Button.

Reinsert removed power wire into terminal block and tighten screw to secure. Unit will sound one (1) tone. Release Reset Button after you hear tone.

The Master Code is now reset to default (1251).

Step 4 - Reinstall keypad unit in junction box and fasten mounting screws.



Call (972) 474-6390
 Email techsupport@securitybrandsinc.com
 We are available **Mon-Fri / 8am-5pm Central**

