

XL 660



S-XL-660

660-CODE KEYPAD

FEATURES

- Control up to 2 gates/doors
- 660 four-digit code capacity
- "3 strikes, you're out" security
- Personal master code
- Latch code
- Variable relay time
- Event input
- Audible-tone feedback
- Non-volatile memory
- Lighted keypad



ADVANTAGE FAMILY

SOLID KEYPADS FOR OVER 30 YEARS

NO-NONSENSE OPERATION

If you're looking for a keypad that is easy to program and easy to use, look no further!

FEATURE RICH FOR LESS

Connect two devices, set a latch code, and enjoy the convenience of an event input, all at a budget-friendly price.

STURDY & DURABLE

Crafted exclusively from stainless and powder-coated steel, this unit is built to last!

PROGRAMMING YOU KNOW

Quick, simple, and familiar, the basic programming steps on the keypad are identical to those on all of our keypads.



SPECIFICATIONS

PHYSICAL

Dimensions 5.41"(H) x 4.07"(W) x 3.38"(D)
 Shipping Weight 4 lbs.

ELECTRICAL

Input 12-24 VAC/DC
 Current Draw less than 40 mA @ 12 VDC
 less than 22 mA @ 24 VDC
 standby with keypad lit
 less than 67 mA @ 12 VDC
 less than 35 mA @ 24 VDC
 with relay latched

RELAY

Contact Rating 1 A @ 24 V / .5 A @ 120 V
 DC Load / AC Load
 Max Switching Voltage 150 V / 220 V
 Max Carrying Current 2 A / 2 A
 Max Switching Power 28 W / 60 VA
 Variable Relay Time 1-999 seconds

ENVIRONMENTAL

Operating Temperature -15 to 175 °F

MOUNTING

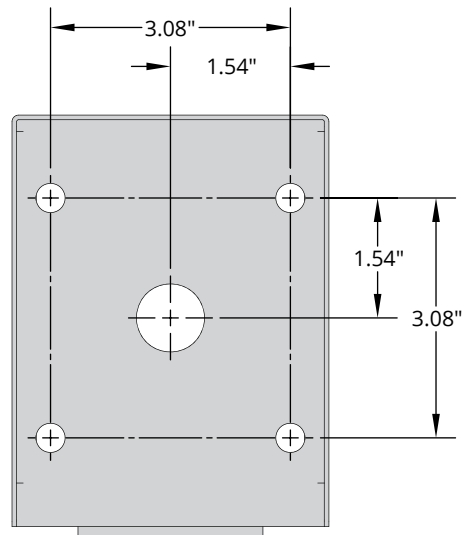

Hole Sizes

Wiring pass through 0.88"
 Mounting holes (4x) 0.38"

Unit includes mounting hardware.

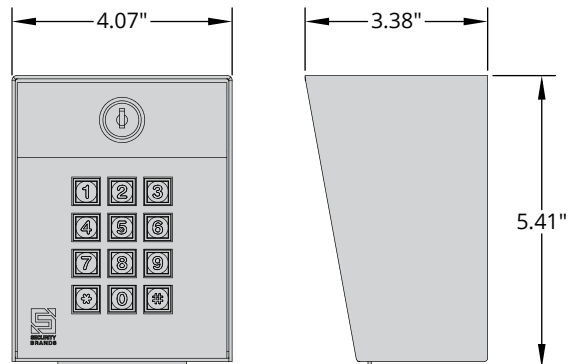

RELATED PRODUCTS



Advantage DKE
 100-Code Economy Keypad
26-100sg



Ascent K1
 Cellular Keypad
25-K1



Ridge 2.0
 Wireless Keypad & Transceiver
S-14-500